

How to fight CBI with long bunches and Landau cavities

M. Eriksson

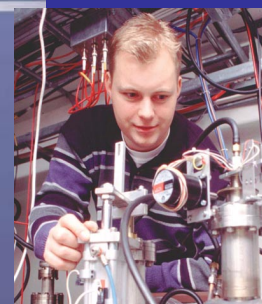

100 MHz Capacity-loaded Cavity for MAX-II and -III, F = 100.08323 MHz

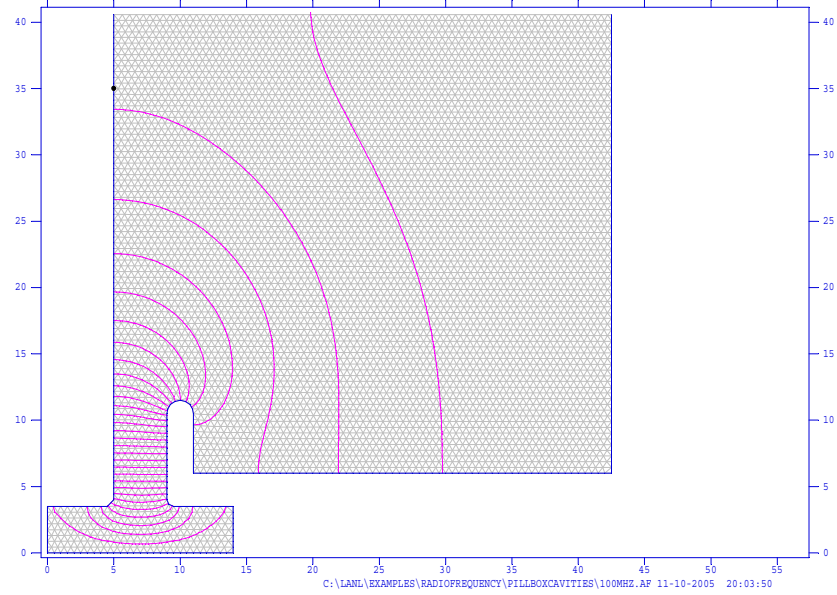

100 MHz Capacity-loaded Cavity for MAX-II and -III, F = 455.96217 MHz

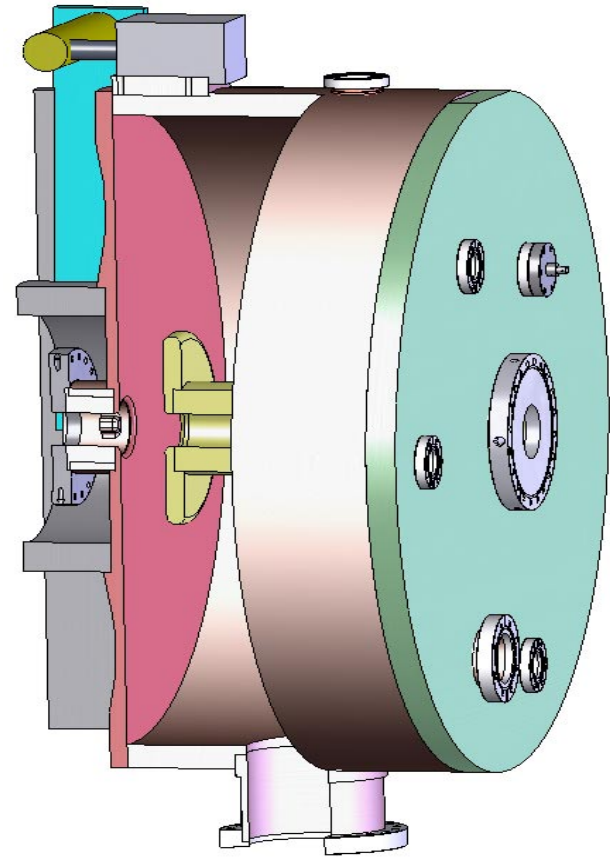
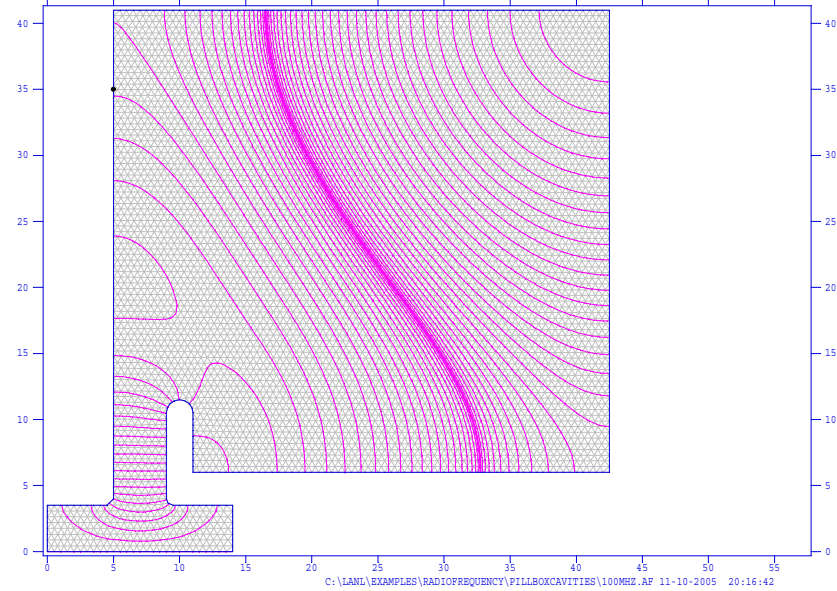

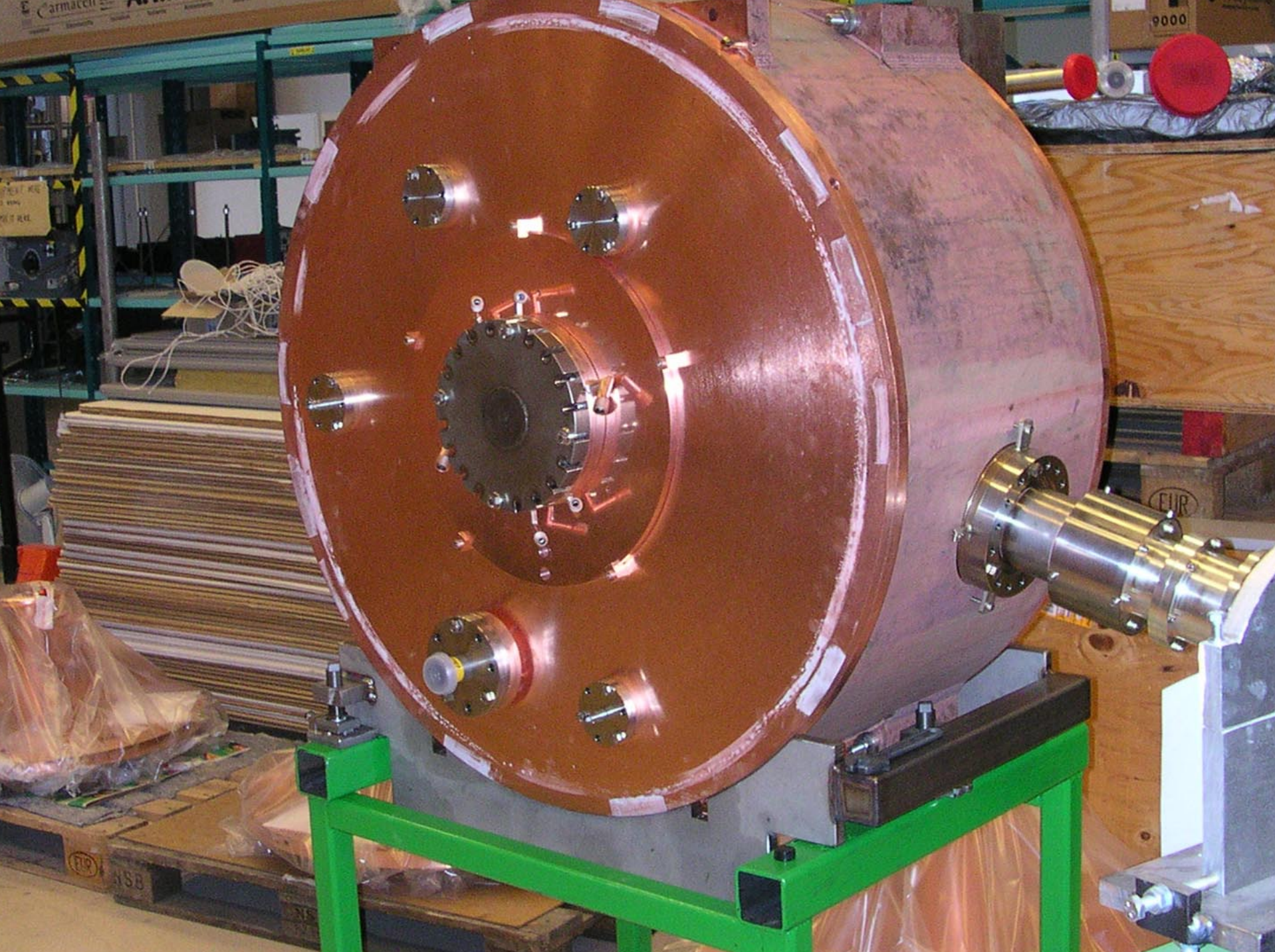



FN: 10353
ID: 20801
2345-15

FN: 10353
ID: 20801K
2345-15
238499

Results so far at MAX II

- Bunches stretched from 3 cm to 10 (RMS)
- Lifetime from 3-4 to 6-8 Ah
- One injection/day, 250 mA drops to 130 the day after
- No CBI seen
- Less He-boil-off in SC wigglers
- Micron or sub-micron vertical beam stability
- But still, much to be gained with a full-energy injector

Transverse power spectrum

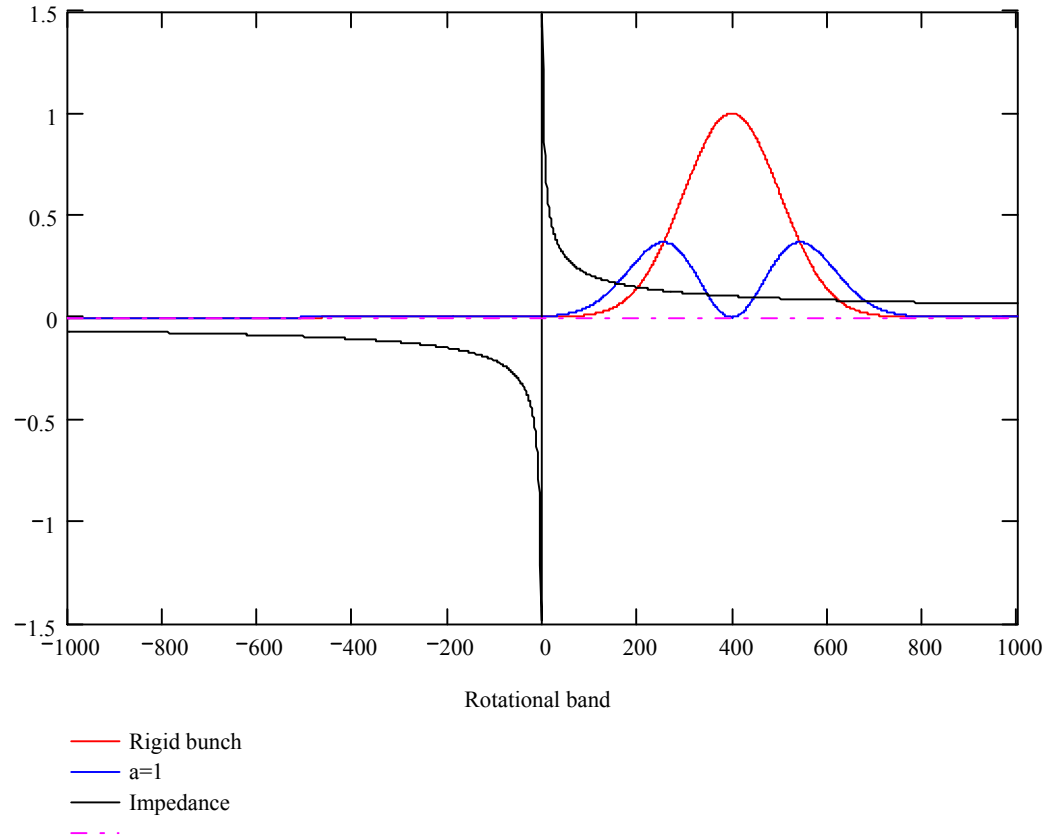

Power spectra and impedances, Bunch-length=10 cm

Transverse power spectrum

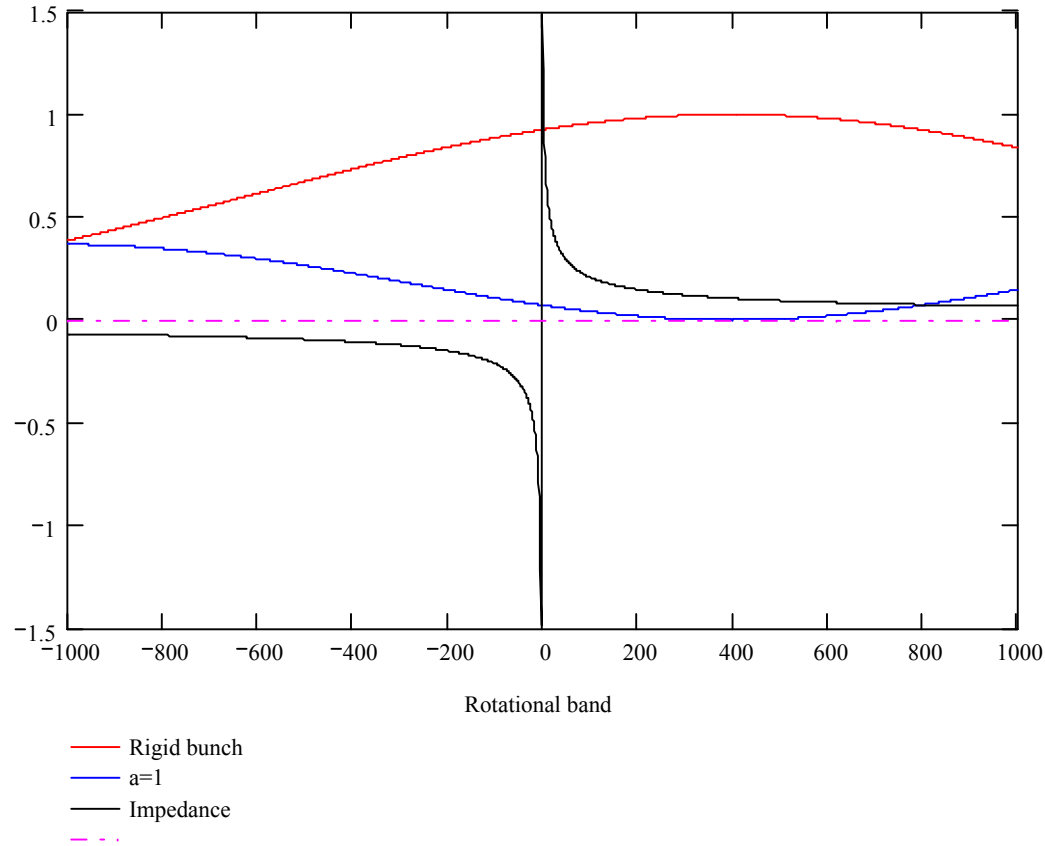

Power spectra and impedances, Bunch-length=1 cm

Max long impedance/cavity

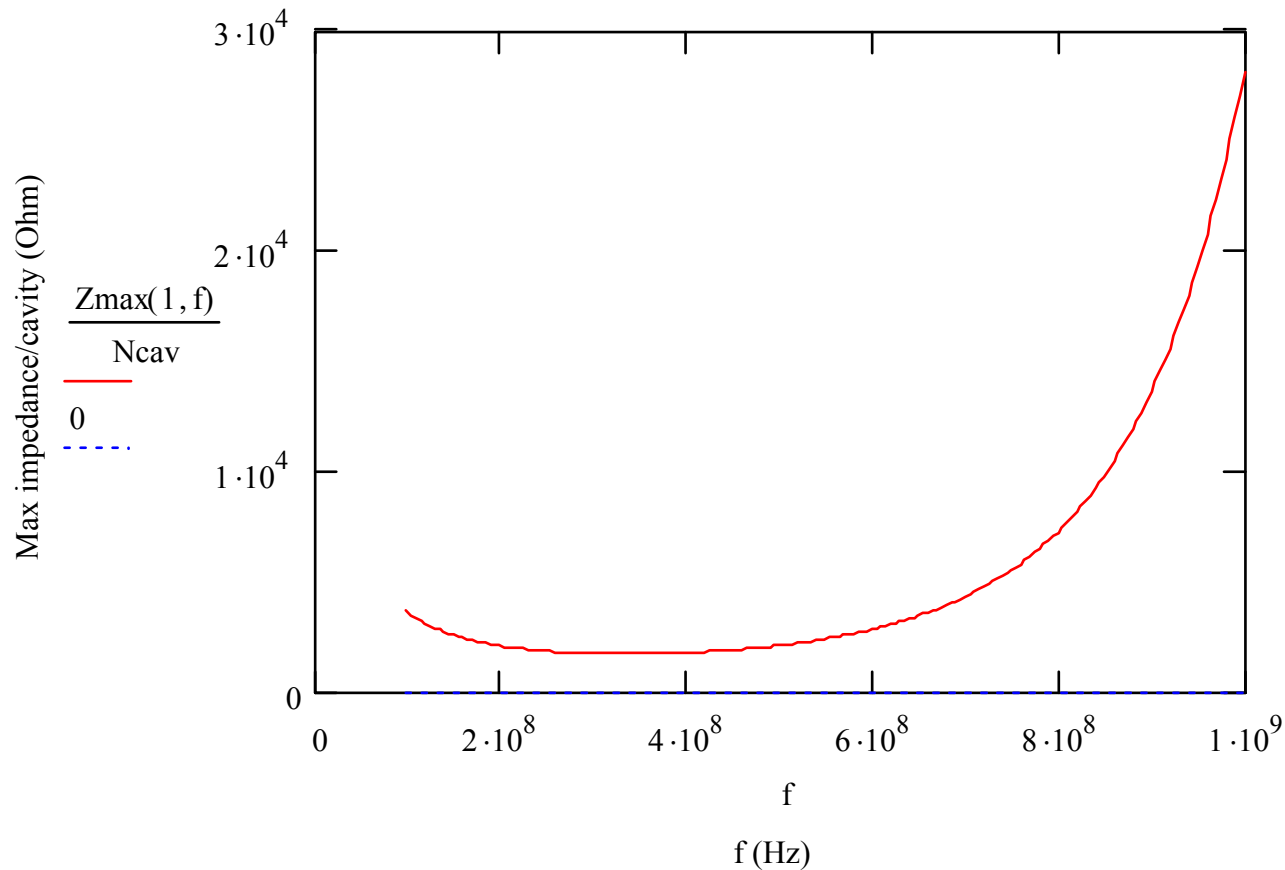

Maximum long impedance as a function of frequency
(100 MHz cavity)

Measured long impedances

Measured f [MHz]	Measured Q	R_{shunt} [k Ω]
406.26	<300	-
451.99	320	2.55
605.79	<300	-
801.77	1250	6.91
847.01	5750	1.36
907.2	700	1.93
1187.53	3880	20.34
1251.66	1400	0.77
1435.89	4860	112