

SOLEIL Low level RF system

Existing:

- SOLEIL main parameters
- Booster amplifier
- Booster RF control system
- Booster and storage ring low level RF system

Under development :

- Future digital low level RF of storage ring
- Microphonic measurements
- Direct and digital feedback simulation model
- Transverse feedback under development

SOLEIL main parameters

	2 (1) cryomodules
RF frequency (MHz)	352.202
Harmonic number	416
Nominal energy (GeV)	2.75
Energy loss per turn (keV)	1050 (950)
Momentum compaction factor	$4.38 \cdot 10^{-4}$
Energy damping parameter, D	$6.88 \cdot 10^{-4}$
Cavity loaded quality factor	10^5
R/Q per cavity (Ohm)	45
Beam current (mA)	500 (300)
Total cavity voltage (MV)	4 (3)
Synchronous phase ($^{\circ}$)	73.6 (71.5)

Booster Amplifier :

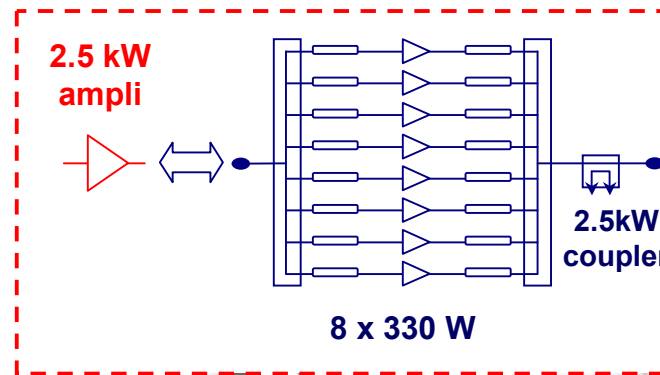
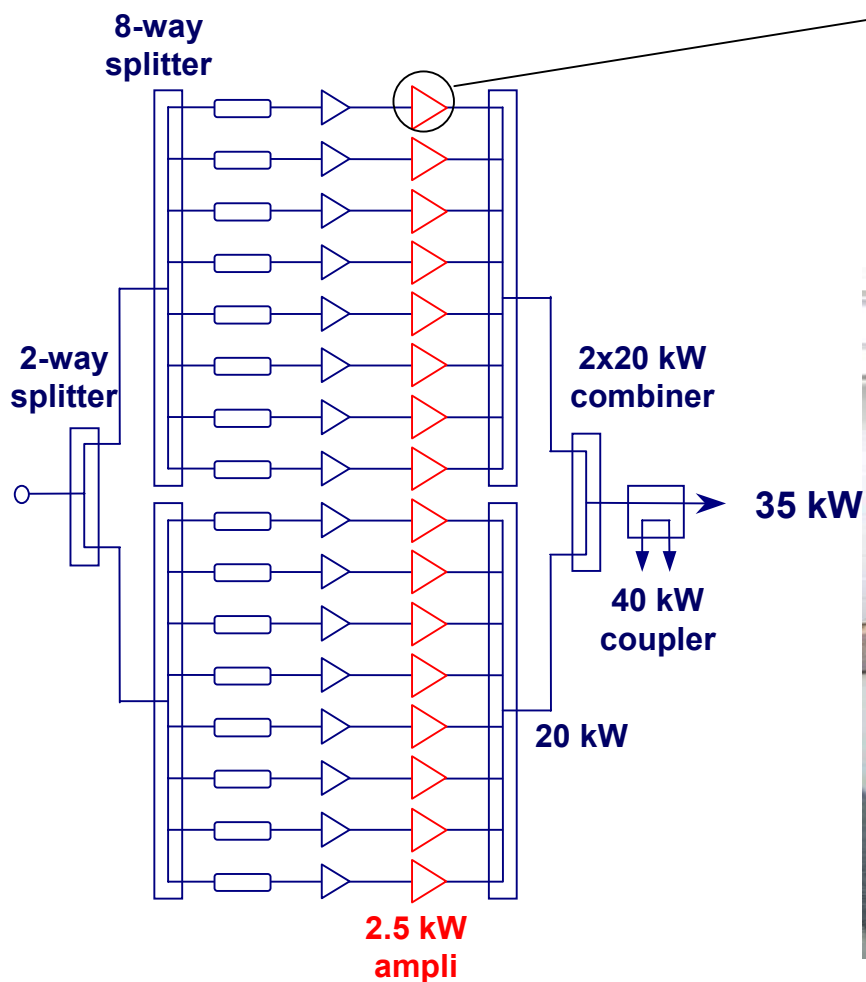

$(18 \times 8) + 3 = 147$ modules

Booster RF control system

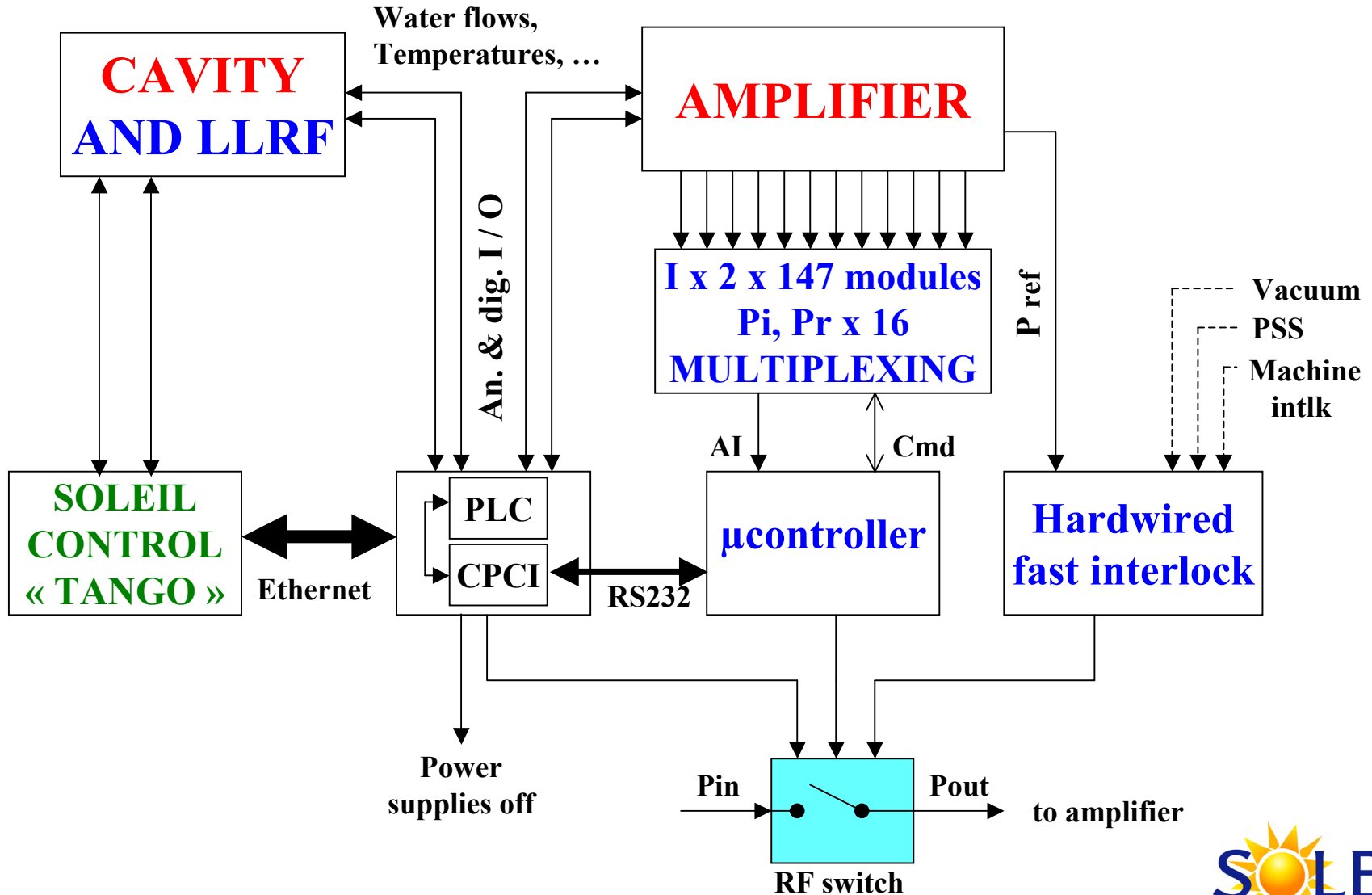

Amplifier monitoring display



Dissipater n°

I_{1,2} for the 9 upper modules

Pi, Pr @ 2.5 kW

I_{1,2} for the 9 lower modules

1st stage or stand-by

Booster LLRF system

3 conventional « slow » control loops for the frequency, amplitude & phase remake of a LURE design adapted to the SOLEIL needs

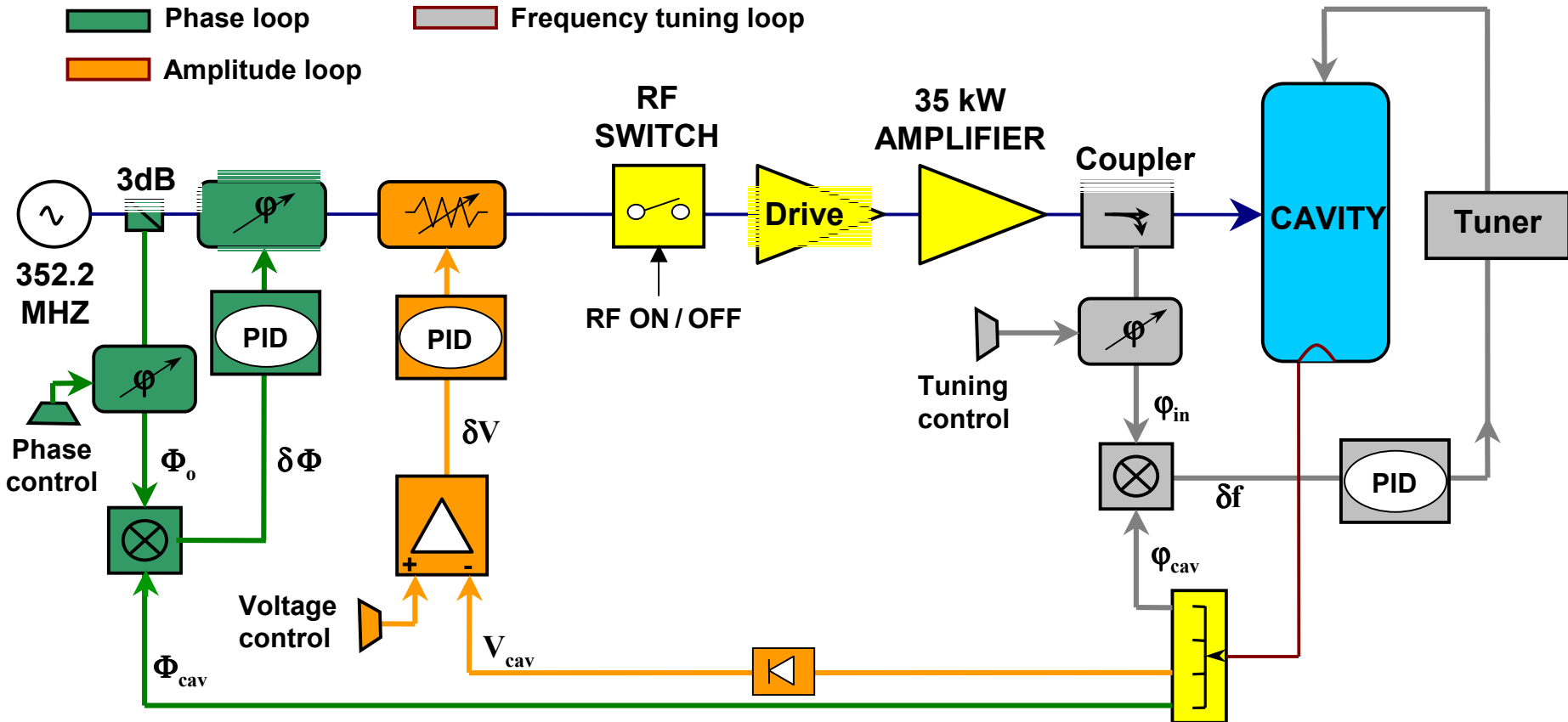

	Amplitude	Phase	Frequency
Accuracy	$\pm 0.25 \%$	$\pm 0.4^\circ$	$\pm 30 \text{ Hz}$
3 dB BW	3 kHz	1.5 kHz	5 Hz

Storage Ring LLRF system phase 1

SR LLRF = BO LLRF + direct RF feedback

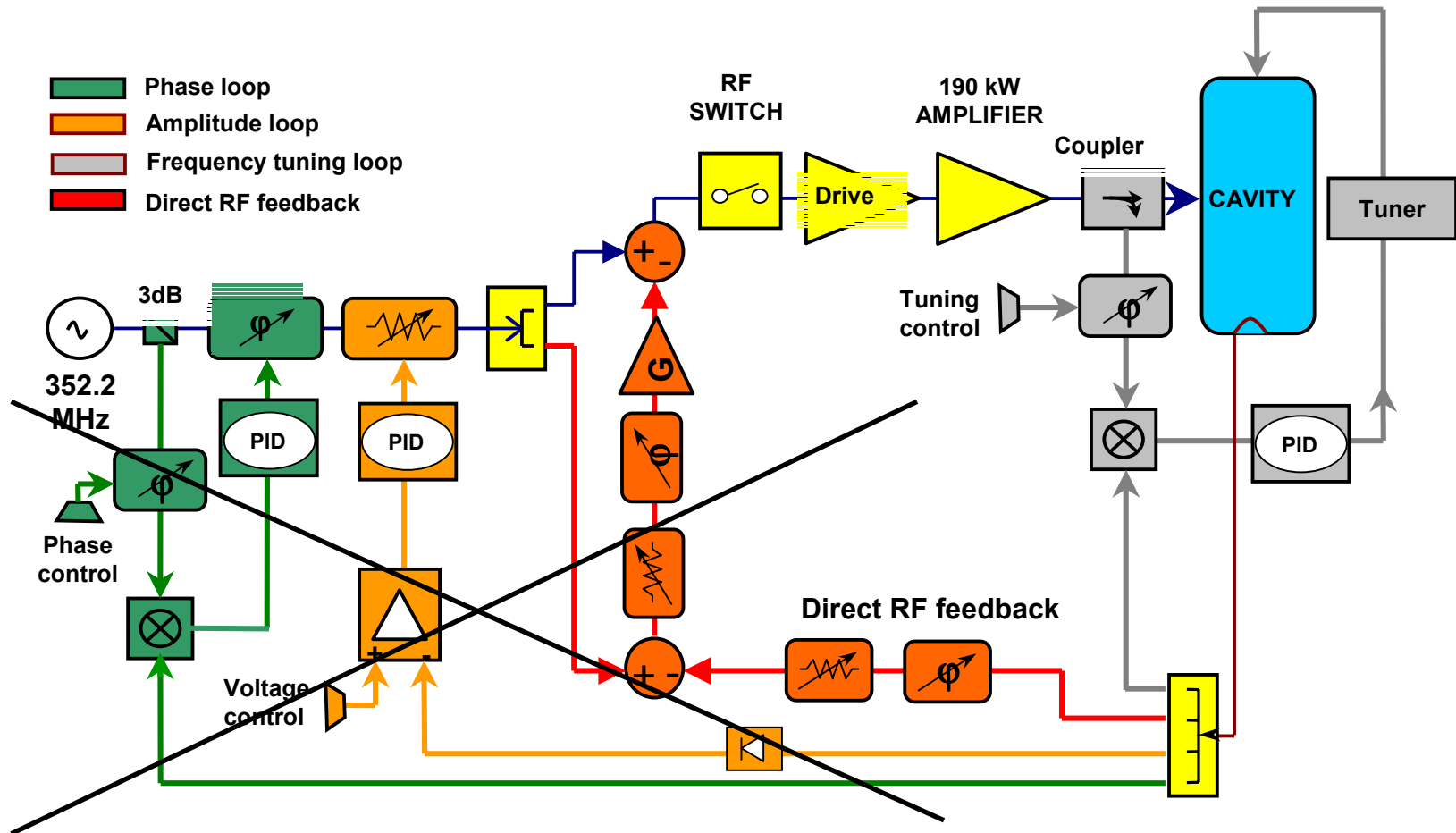

Storage Ring digital LLRF Phase 2

al (FPGA based) phase and amplitude loops,
development in collaboration with CEA

Filtering
unit

VCO

Digital unit
(ADC-FPGA-DAC)

I-Q
modulator

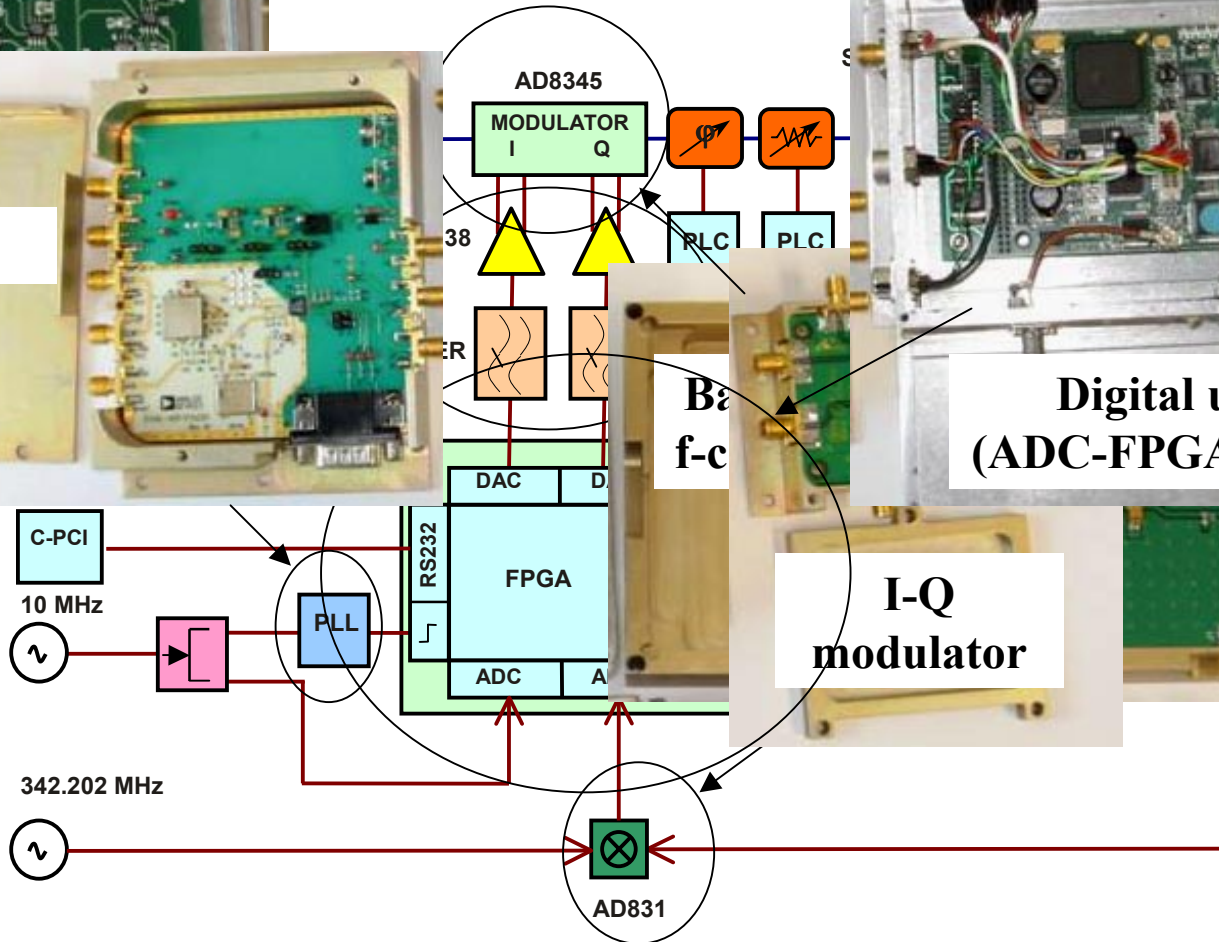

Architecture of FPGA

Module Architecture

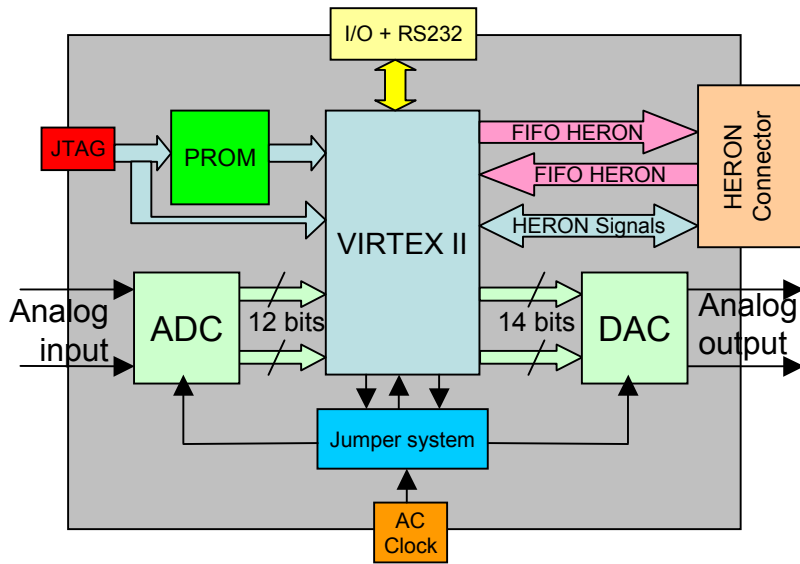

Heron IO2V2 board

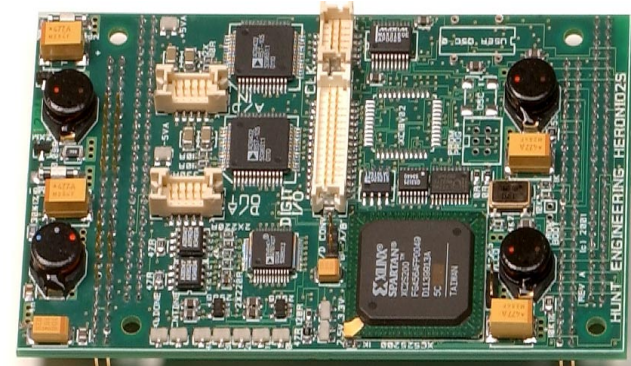

FPGA Architecture Design

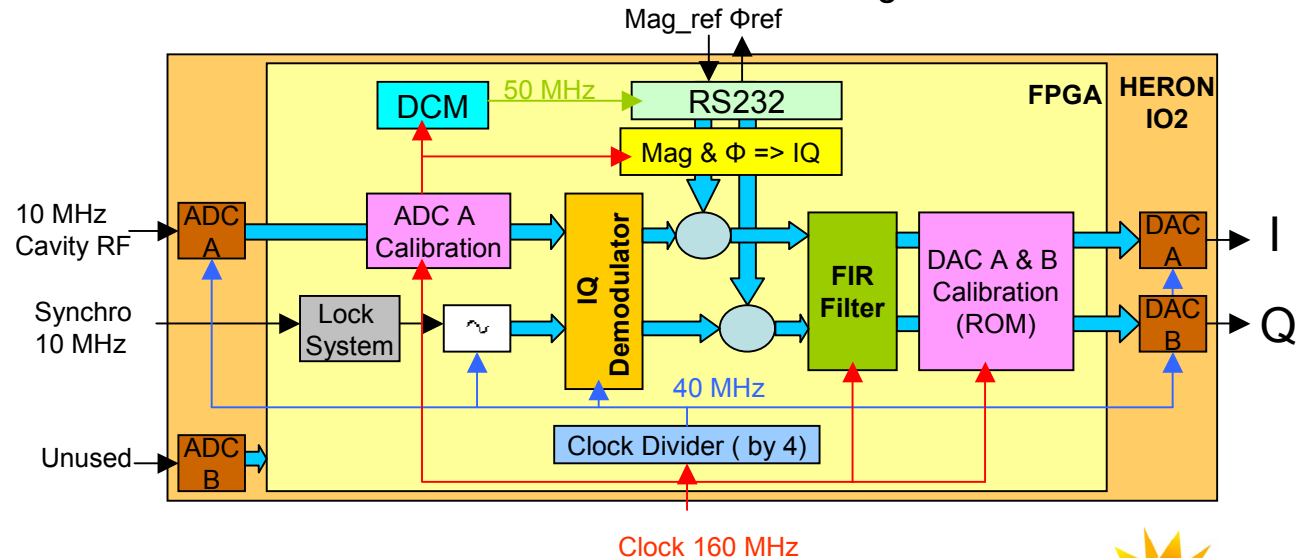

Digital IQ Demodulator

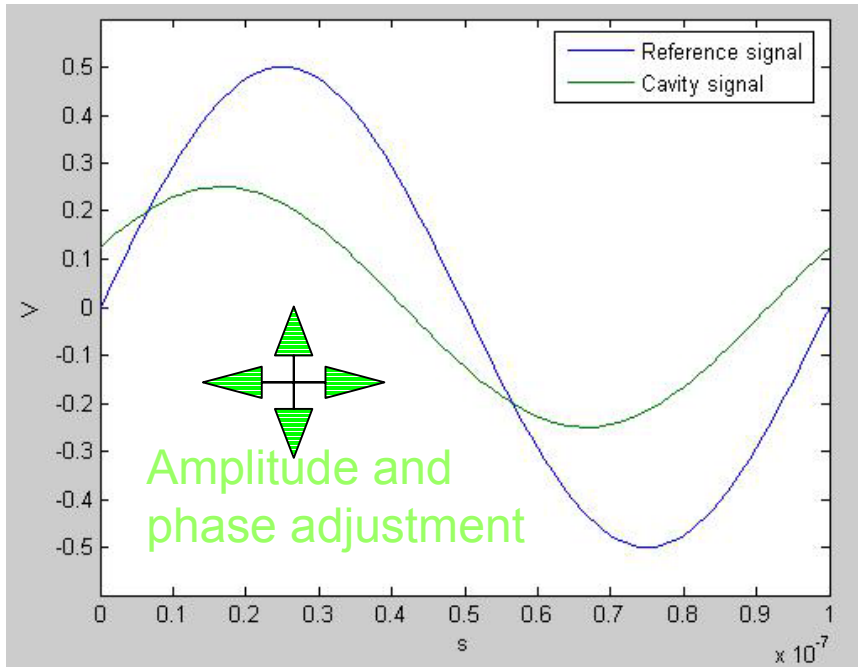

The experiments shows that we cover 0 to 360° as shown with different amplitude.

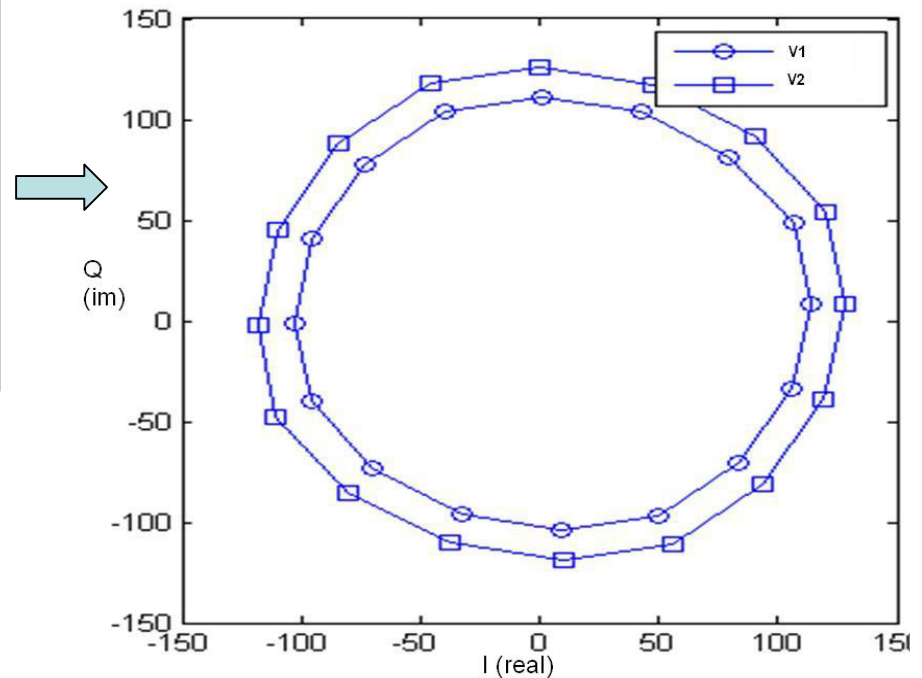

Low pass FIR filter

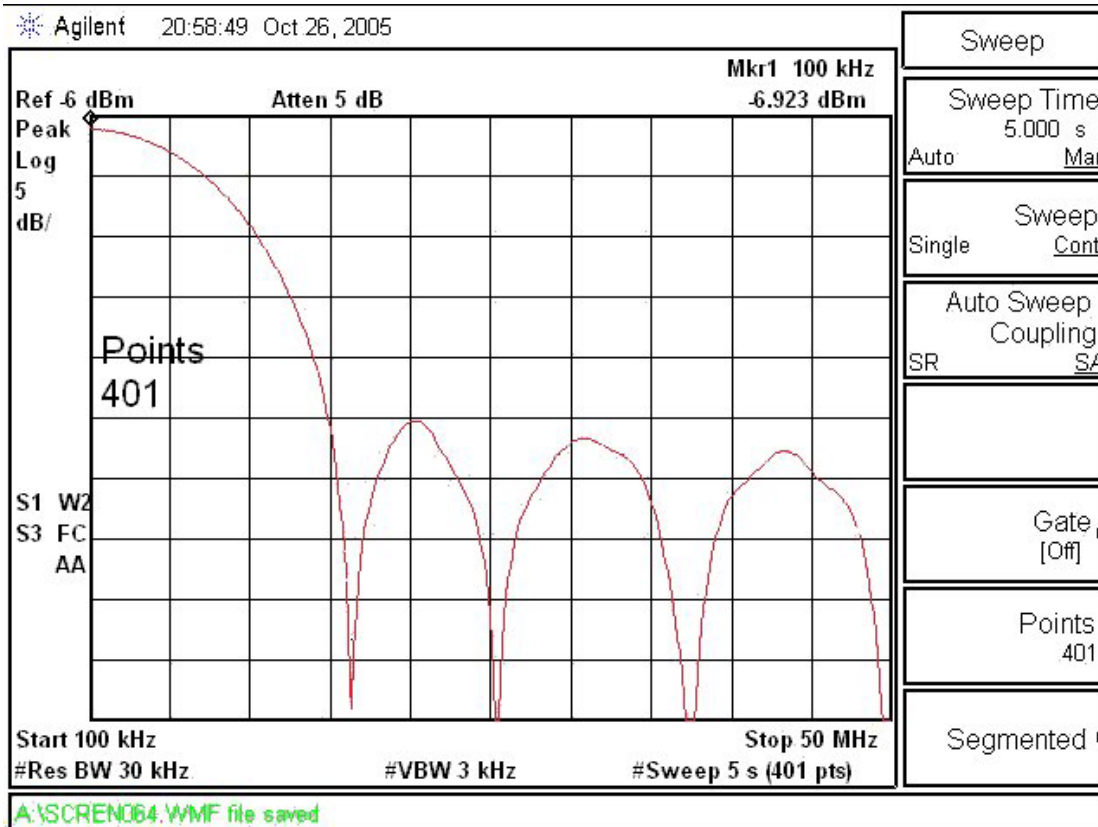

FIR filter was simulated with MATLAB Toolbox which provides a filter coefficients file. This file is added in ISE project root for FIR filter.

The theoretical results agree with the measurements, as shown.

Microphonic measurements

Cavity spectrum

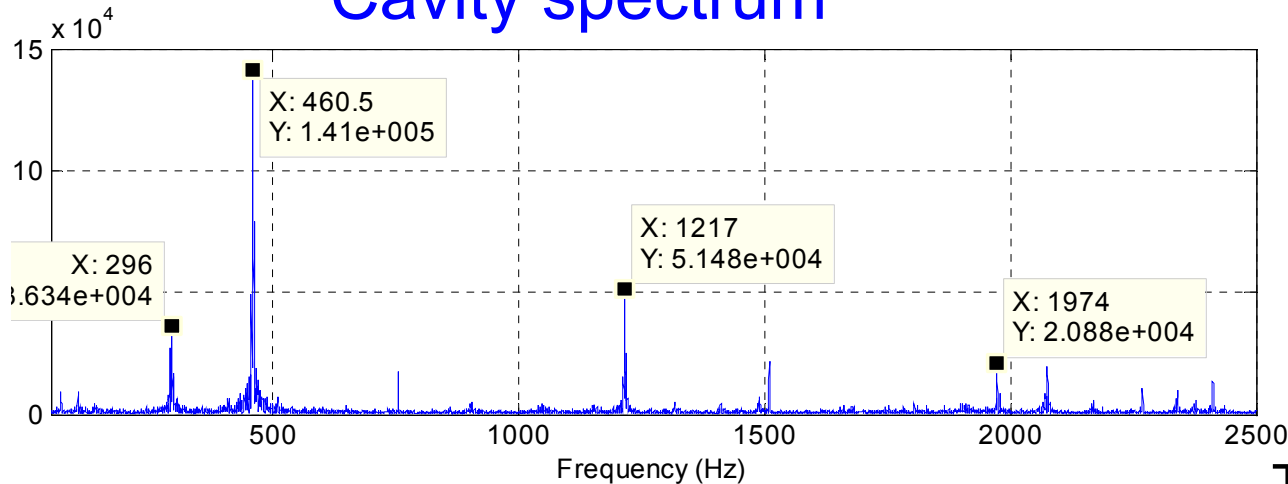

Method :

Measurements of cavity microphonic using phase detector on tuning loop.

Cavity 2D spectrogram

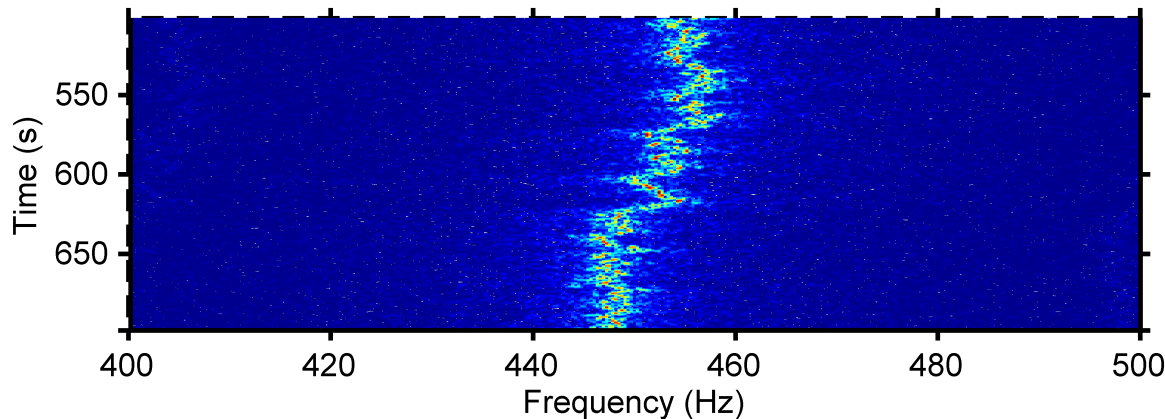

The major disturbance, around 460 Hz, is likely related to a mechanical eigenmode of the cavity

The eigenfrequency associated to this mode may change according to the helium pressure.

Direct and digital feedback simulation model

First order cavity model

$$\dot{V}_{cr} = \frac{1}{\tau} [V_{gr} - V_{cr} - \tan\psi \cdot V_{ci}]$$

$$\dot{V}_{ci} = \frac{1}{\tau} [V_{gi} - V_{ci} + \tan\psi \cdot V_{cr}]$$

Beam loading

$$V_{cr}^+ = V_{cr} + \omega_{RF} \left(\frac{R}{Q} \right) q \cos\phi_b$$

$$V_{ci}^+ = V_{ci} + \omega_{RF} \left(\frac{R}{Q} \right) q \sin\phi_b$$

Synchrotron motion

$$\Delta E_i^{n+1} = \Delta E_i^n - V_c \cos[\phi_{b0} + (\delta\phi_b)_i^n - \phi_c] - (U_0 + D \Delta E_i^n)$$

$$(\delta\phi_b)_i^{n+1} = (\delta\phi_b)_i^n - \frac{2\pi f_{RF} \alpha}{f_0 E_0} \left\{ \Delta E_i^n - V_c \cos[\phi_{b0} + (\delta\phi_b)_i^n - \phi_c] - \frac{U_0 + D \Delta E_i^n}{2} \right\}$$

Direct feedback

$$\tilde{V}_g = \tilde{V}_{g0} + G (V_{c0} - \hat{D} \tilde{V}_c)$$

Fast I/Q feedback

$$\tilde{V}_g = \tilde{V}_{g0} + G_I (V_{c0} - \hat{D} V_{cr}) - j G_Q \hat{D} V_{ci}$$

Disturbed beam stability study

Disturbance parameters used in simulation

Injection phase error (°)	5
Relative injection energy error (%)	-0.1
'Real' microphonics (~200 Hz pk-pk detuning)	

No feedback

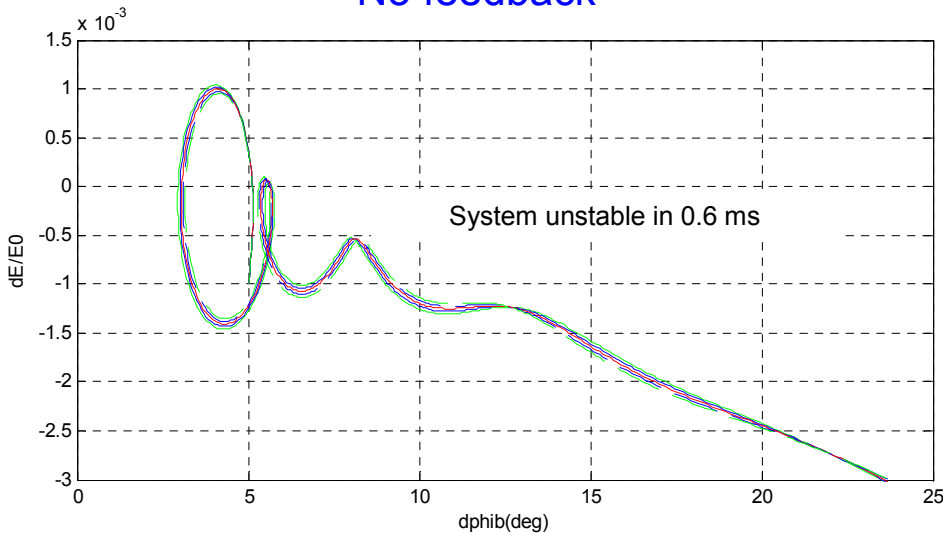

Direct RF and Digital I/Q feedback loop performances

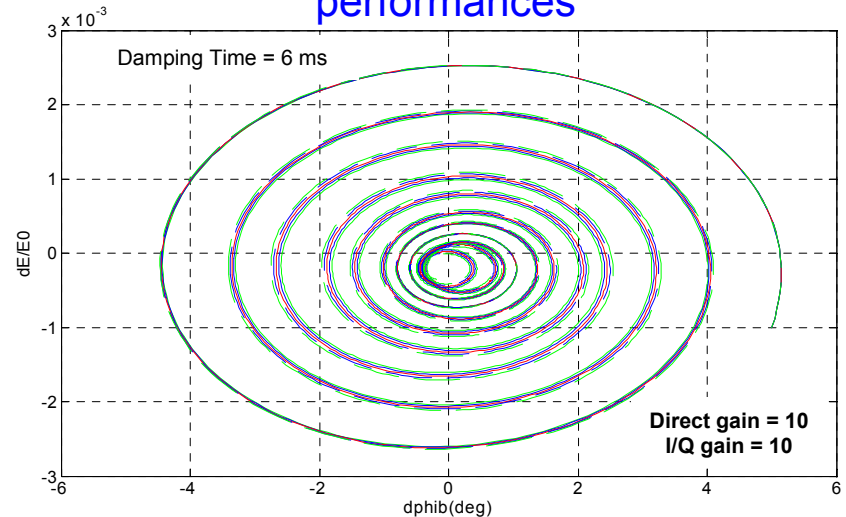

Stabilized steady state :
microphonics
disturbance included

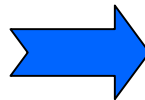

Cavity phase residual error	0.6 ° pk-pk
Cavity voltage residual error	0.08 %

Transverse feedback under development

Multibunch transverse feedback:

To deal with multibunch instabilities

Status : starting of this project

Transverse feedback under development

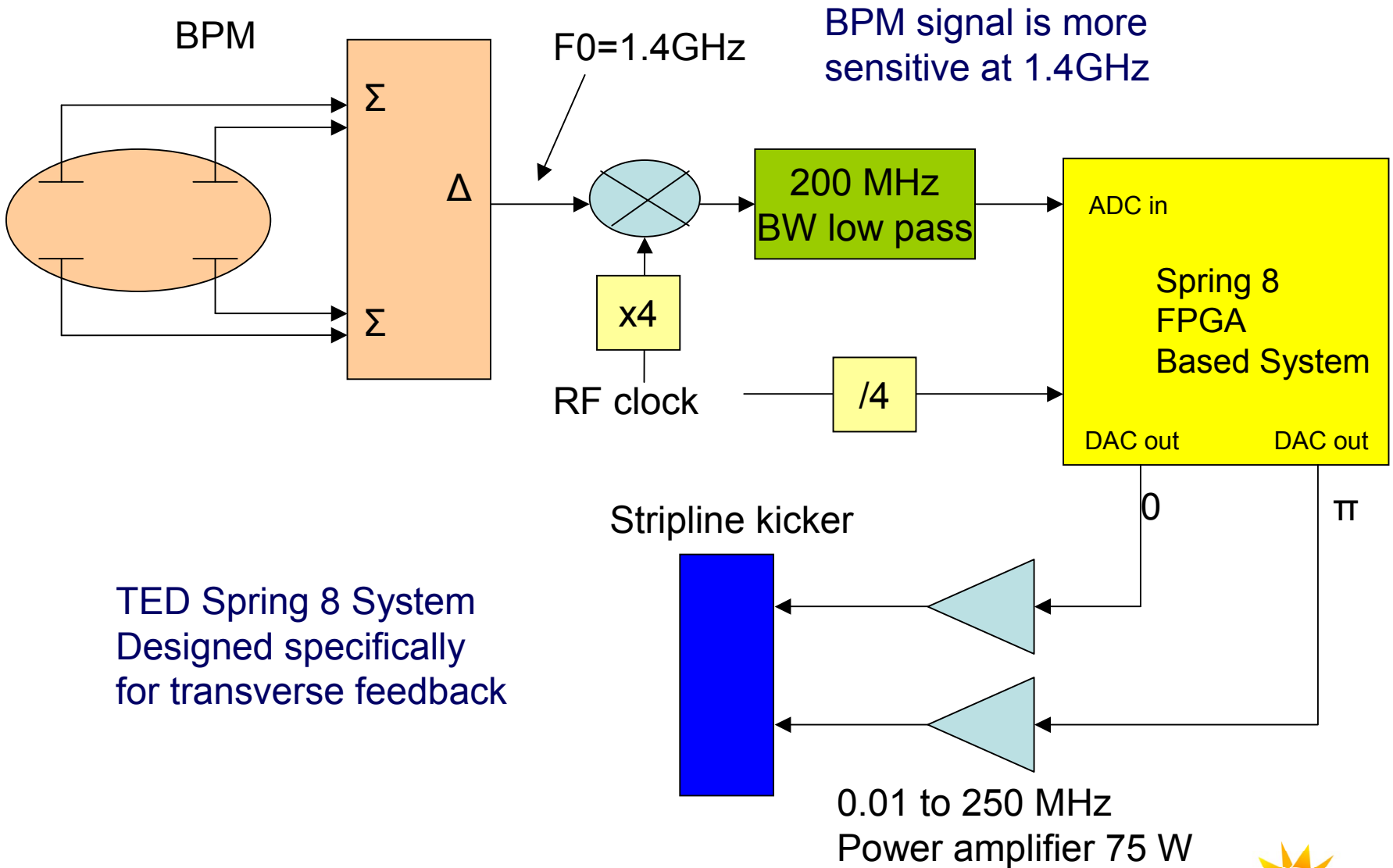

TED Spring 8 System
Designed specifically
for transverse feedback